

## **Mechatronics Engineering Laboratory Development at San Jose State University**

J.C.Wang, B.J.Furman,  
T.R. Hsu, P.Hsu, P.Reischl and F.Barez

Departments of Electrical Engineering and Mechanical Engineering  
San Jose State University  
San Jose, California, 95192. USA.

### **Abstract**

The Mechanical Engineering Department of San Jose State University has been developing a new mechatronics engineering laboratory since Fall 1995. This laboratory is intended to provide engineering students on the application of electronics, microprocessors and software in designing electro-mechanical systems, mechatronics products and process control systems. The laboratory development is a principal part of an award for “ Undergraduate Curriculum Development on Mechatronics System Engineering ” by the division of undergraduate education of the National Science Foundation (NSF). Major task of the new laboratory is to support instruction and provide hands-on study of two of the five new courses : ME106 Fundamentals of Mechatronics System Engineering and ME 190 Mechatronics System Design. This paper presents the progress made in developing the new mechatronics engineering laboratory.

### **1. Introduction**

The rapid advances of microprocessor and microcomputer technologies in the 1980's have broadened the application of mechatronics to many products and systems, ranging from common household electromechanical products to highly sophisticated space gadgetry and devices. A broader definition of Mechatronics being adopted by the team of instructors at San Jose State University ( SJSU ) is that mechatronics is a technology that relates to the design and manufacture of intelligent products or processes involving hybrid mechanical and electronic functions.

A taskforce involving the faculty members from mechanical, electrical, computer and general engineering departments, and members of the Mechanical Engineering Department Advisory Board was established in early 1993. This taskforce had a mission to develop an undergraduate curriculum in mechatronics that would satisfy the needs of Silicon Valley high technology industry.

The new curriculum will become the third curriculum stem in the Mechanical Engineering Department starting fall-1997. Presently, we offer two stems in the department. These are : (1) Mechanical Engineering Design, and (2) Thermofluids. The implementation of this new stem required the effort in development of the following five new courses :

ME 106 Fundamentals of Mechatronics Engineering ( 4 units, Lec/Lab )

ME 190 Mechatronics System Design ( 3 units, Lec/Lab )

ME 136 Design for Manufacturability in Electronic and Computer Equipments ( 3 units,  
Lec/Lab)

ME 196M Introduction to Micro-manufacturing ( 3 units, Lec/Lab)

ME 196P Control of Manufacturing Process ( 3 units. Lec/Lab)

In addition to the five new courses as listed above, significant modification are made on two existing courses on :

ME 187 Automatic Control System Design ( 3 units )

ME 196E Robotics and Digital Control of Modern Manufacturing ( 3 units, Lec/Lab).

The course ME 190 is designated as the capstone course for the new curriculum stem as required by the ABET. Two other existing courses offered by the existing curriculum stems in the department will also be designated as Mechatronics courses. These are :

ME 196K Cooling of electronic Systems ( 3 units, Lec/Lab)

ME 196L Design for Electronic Packaging ( 3 units, Lec/Lab )

Detail description and contents of these nine courses can be found in Ref.[1].

The proposal to develop the five new courses and the new mechatronics system engineering laboratory was forwarded to the Undergraduate Course and Curriculum program of the Division of Undergraduate Education of the NSF in June, 1994. Award of funding was announced in early 1995.

## **2. Development of the Mechatronics Engineering Laboratory**

Since the development of the Mechatronics Engineering laboratory was carried out in conjunction with the curriculum development of ME 106 and ME 190, it will be helpful to discuss both in this section. Our development activities for the two courses consisted of :

- \* Defining the course content
- \* Define specific experiments to support the course content
- \* Define equipments and components for the Mechatronics Engineering laboratory.

Subsequent sections of this paper will address each course individually and then describe the laboratory that supports both courses.

### **ME 106 Fundamentals of Mechatronics Systems Engineering**

This course is the first core course in the mechatronics curriculum stem. This course is offered in spring, 1996 and 1997. The objective of this course is to help the students gain a solid grasp on the fundamental aspects of the mechatronics technology. These includes basic analog and digital electronics, sensors and transducers, power drive devices, microcontrollers and programming. Prerequisites include “ Introduction to Electrical Circuit Analysis,” “ Mechanics: Static and Dynamics ,” “ Basic Programming, “ and “ Differential Equations.” Junior and senior level students from the Mechanical Engineering Department make up the bulk of those taking this course. This is a lab/lecture course with two one-hour lectures and three hours laboratory learning every week The present text book used for the course is " Electromechanical Engineering: An Introduction " by C.Fraser and J.Milne. IEEE Press, 1996. The lab manual is provided by our faculty.

## ME 105 Course Outline

### Week 1- Introduction to Mechatronics

Mechatronics case study, introduction to the Mechatronics Engineering Laboratory.

### Week 2- Review of Basic Electronics

Ohm's law, semiconductors (PN junction diodes, AC rectification, Zener diode), power supplies.

### Week 3- Principles and Applications of Transistors and Operational Amplifiers

Transistor (common emitter characteristics, emitter follower circuit, FET); thyristor; triac; operational amplifiers (inverting, unity gain, non-inverting, C/V and V/C amplifiers, differential amplifier, instrumentation amplifier).

### Week 4- Digital Electronics

Boolean algebra; digital electronic gates; combination logic systems (simple gates, NAND and NOR gates, latches, positive and negative logic, tri-state logic); sequential logic systems (J-K flip-flop, registers and counter, timers and pulse circuits).

### Week 5- Sensor and Transducer Principles

Introduction to sensors and transducers; general transducer characteristics (performance characteristics, static and dynamic characteristics); calibration; signal conditioning.

### Week 6- Sensor and Transducer Applications

Measurement of: angular position, linear displacement, rotational speed, force, pressure, strain, flow rate, temperature.

### Week 7- Drive Technology Principles

Physical principles; solenoid-type devices; DC machines; AC machines; stepper motors.

### Week 8- Drive Technology Applications

Linear motors; voice coil motors; electro-pneumatic and electro-hydraulic actuators.

### Week 9- Electromechanical System Principles

Rotary to linear motion conversion; power transmission.

### Week 10- Electromechanical System Applications

Coupling; gearing; belts; pulleys; bearings.

### Week 11- Introduction to Microprocessors

Basic architecture, CPU, memory, I/O ports.

### Week 12- Microprocessor Interfacing

Bus timing, A/D, D/A conversion.

### Week 13- Microcontroller Programming

Basic C programming, real-time programming.

### Week 14- Microcontroller Applications

Class projects.

### Week 15- Mechatronics Case Study

## ME 105 Laboratory Experiments

The goal of the laboratory experiments is to provide the students with hands-on learning of basic subjects introduced in the lectures. Laboratory instruction for each experiment is distributed to each group of students every week. A formal laboratory report is required from each group. Careful laboratory assistance is provided each week by a graduate teaching assistant and a faculty member. A total of 12 experiments are listed below. The experiments lead the students to build and experiment simple electro-mechanical systems, analog control of mechanical systems, and toward more complex microcontroller controlled mechatronics systems.

Week	Lab Title	Purpose and Projects
1	Light-Controlled Switch	Introduce basic electronic components and instrumentation ( resistors, potentiometers, photoresistor, LED, transistor, DMM, power supply ) . Build and test light-controlled switch.
2	Electronic Scale	Introduce operation of function generator and oscilloscope and applications of operational amplifiers. Build an electronic scale using prefabricated cantilever beam with attached strain gauge.
3	Analog Temperature Controller	Introduce analog closed-loop control and application of IC temperature sensors. Build a temperature controllers for a pre-instrumented thermal mass.
4	Digital Counter	Introduce digital IC's and optoelectronics. Build a digital counter with seven-segment display unit.
5	Inclinometer	Introduce the concept of transducer calibration and the use of potentiometers for angular rotation measurement. Build an inclinometer using a pot to determine an unknown angle.
6	Printer Carriage Control	Introduce photoreflexive, optointerrupter, and mechanical switches as limit switches. Build a switching device to provide reciprocal motion of a printer carriage between two limit switches by a dc motor.
7	DC Motor Speed Control	Introduce dc motors, tachometers, analog closed-loop speed control. Build a dc motor analog speed controller.
8	Industry Tour	Tour facilities of local mechatronics company.
9	Introduction to C Programming	Introduce C programming. Write, compile, download a simple C application program to the microcontroller board.
10	Digital Temperature Control	Introduce real time digital feedback control. Build a digital temperature controller for a pre-instrumented thermal mass ( see Lab #3).
11	Microprocessor Controlled Parts Sorter	Introduce multi-input, multi-output, microcontroller control of an electromechanical system.
12	Microprocessor Controlled Parts Sorter	Continuation of Experiment # 11.

Three laboratory experiments are briefly presented below :

Lab#1 introduces students to voltage, current, and resistance measurement. The objective of the lab is to help the student to learn the functions of the digital multimeter and introduce them to three basic electronic components : the photoresistor, the light emitting diode ( LED ), and the transistor. First the student is required to obtain the basic electrical characteristic data ( resistance , current and voltage ) of each component under different power supply condition. Next a project is given to the student to design, construct, and test a light-controlled switch for a typical automatic out-door lighting equipment. Fig.1 shows a light-controlled circuit. This circuit turns the LED on when the light intensity is low. For the selected set of electric components, the student is asked to determine and verify the best power supply voltage for a stable operation of the circuit.

The final two experiments , Lab #11 and Lab #12 lead students to microprocessor controlled parts sorter. This project is designed to integrate all knowledge learned by the students in this courses . Fig.2 shows the schematic diagram of the experimental station. This experiment uses the Motorola HC11 to control a DC-motor driven conveyor belt. This microcontroller will sort objects using signals from three photoemitters/photodetectors, and manipulate a stepper motor and electromagnetic robot arm to move the sorted part to the designated bin. Three photoemitter/detector pairs are mounted on the sides within 1 " apart from each other. A part placed on the conveyor will move through three photoemitter/detector pairs. As the parts reaches the sensor nearest the robot arm, the size of the part is detected. After the size of the object is determined, the controller will trigger relays on the relay board to turn off the DC motor. The microcontroller will then turn on the electromagnetic robot arm to pick up the part, move the stepper motor at the base of the arm by the correct number of steps, then turn off the electromagnet of the arm and therefore place the part into the designated bin. Finally, the HC11 will return the stepper motor to its original position. After the cycle is completed a new part is again placed onto the conveyor , and the control cycle repeats. The student is required to interface all components to the HC 11 microcontroller board , write application program in C language, compile and download the program from a PC to the HC11 for the demonstration of the microprocessor controlled parts sorter [2].

### **ME 190 Mechatronics System Design**

ME 190 is the capstone course in the stem open to senior level students, and is intended as the follow-on course to ME 106. It is an open-ended project oriented course which expands on the fundamentals presented in ME 106 and emphasizes the application of microprocessors for motion control, smart product design, and automatic digital process control. The course is designed to support the students as they develop their projects. Laboratory projects are based more on realistic industrial problems rather than simplified laboratory experiments. A typical student project is presented in the next section. Groups of three to four students work collaboratively on three distinct projects of their choice. The first project is related to motion control. The students will select a motion controlled mechanical system. Torque calculation, motion analysis, motor selection, mechanical drive system design, load analysis, controller selection, and computer-aided control system analysis are performed before construction of the final system. The second project relates to smart product design. The students will build a microcontroller controlled product of their own creative design. The last project concerns PC-based process control of flow, temperature, level, pressure, and humidity using common industrial control components. The students will model assigned processes, simulate and design control system with MATLAB software, interface a process, sensors, and actuators to a microcomputer, implement their digital control algorithm, and then test and evaluate the performance of their digital control system with the PC-based controller. Prerequisites for this course are ME 106 and ME 187. The project activity is conducted in three mechanical engineering laboratories : the new Mechatronics Engineering Laboratory, the existing Automatic Control Laboratory and the Automated Manufacturing Laboratory.

- Week 1 - Introduction to Motion Control System, Smart products and Process Control Systems  
Digital motion controlled systems, smart products , control system elements.
- Week 2- Principles and Characteristics of Motors  
Basic of magnetic circuits, types of motors, working principles of motors. DC, AC, stepper motors. Static and dynamic characteristics of motors ( torque and load ).
- Week 3- Motors and Drive Components for Industry Applications  
Mechanical drive components, motor load and inertia calculation.
- Week 4- Power Conversion  
Motor power drives, power amplifiers, electronic servo drive fundamentals.
- Week 5- Sensors for Motion Control  
Encoders, resolvers, decoders, tachogenerators.
- Week 6- Modeling and Response of Motion System with Mechanical Loads  
Motion controller, computer-aided motion control system analysis.
- Week 7- Review of Microprocessor Fundamentals and Programming  
Microprocessor, Basic and C language
- Week 8- Interfacing Mechanical Systems to Microprocessors  
Smart product design case study.
- Week 9- Basic Sensor and Actuators in Process Control
- Week 10-Interfacing Techniques for Digital Data Acquisition and Process Control
- Week 11-Microcontrollers and Microcomputers for process Control System Applications  
Implementation of basic control algorithms for process control.
- Week 12-Intelligent Control Application  
Compare conventional control with intelligent control.

#### ME 190 Laboratory Experiments

Week	Project	Purpose
1	Motion Control	Industry guest speaker on motors and motion control. Selection of motion control projects, torque calculation and determination, motor selection and static and dynamic characterization.
2	Mechanical Drive System	Selection of mechanical drive system, motion specification and motion planning, modeling of the motion control system.
3	Motion Control System Analysis	Computer-aided motion control system analysis, motion sensor system study : calibration, linear and rotary encoders, tachogenerator and interfacing. Construction of a mechanical system.
4	Implementation and Testing	Implementation of motion control system , power units, compensator design, dynamic tuning of controller gains, testing and performance evaluation.
5	Motion Control Project Presentation	Presentation of motion control projects
6	Smart Product Design	Industry guest speaker on smart product design. Selection of smart product design project.
7	Microcontroller Interfacing 1	Build microprocessor interface module.
8	Microcontroller Interfacing 2	Implementation, testing and debug of interface module.
9	Smart Product Design Presentation	Presentation of smart product design projects

- |    |   |  |
|----|---|--|
| 10 | Process Control 1                       | Industry guest speaker on digital process control systems. Familiarization with various sensors, actuators, and process in the Automatic Control laboratory. |
| 11 | Process Control 2                       | Simulation study and Implementation of digital control algorithms for process control with minicomputers   |
| 12 | Process Control<br>Project Presentation | Presentation of process control projects.  |

### **A Student Mechatronics Project**

A senior student project that reflects the objective of this course is presented next. This project relates to the design and manufacturing of a microcomputer-controlled robotics system with force feedback sensors. The intended application of this robotics system is to pick up a raw egg from one position and unload the egg at another specified location for automated egg packaging. The closed-loop robotics system set-up is shown in Fig.3 .

Following are the major activities involved in the project :

- (1) Gripper mechanism design and fabrication ;
- (2) Motor drive system and motion control system development;
- (3) Interface of the motion drive system to the mechanical gripper and also to a microcomputer;
- (4) Force sensor system development and sensor signal analog to digital conversion for the gripper finger motion control;
- (5) Robotic closed-loop system software development for the coordination of manipulator positioning and the continuous force control for the gripper fingers when grasping the object.

This project required the students to apply the knowledge that they acquired in the areas of mechanism and linkages, motion controls, instrumentation, electronics, computer interface and measurement and control software development. A detailed description of the project is available in an internal report [ 3 ].

### **3. Description of the Mechatronics Engineering Laboratory**

Our guiding philosophy in designing the Mechatronics Engineering Laboratory can be summed up in three key statements :

- \* The laboratory should be designed to support a set of experiments to enable application of the concepts presented in the lecture part of course.
- \* The laboratory should have the instrumentation and components to provide a significant hands-on experience for the students ( not an observer's sport )
- \* The laboratory should provided enough space and equipment so that teams of two to three students can work on assigned experiments.

The current laboratory consists of eight work stations. Each station is equipped with a set of basic instruments and softwares for conducting the experiments :

- \* Digital mutimeter ( DMM )
- \* Power supply
- \* Function generator
- \* Oscilloscope
- \* Personal computer

- \* Printer
- \* Multifunction data acquisition and control board
- \* LabView software for data acquisition and process control
- \* MATLAB software
- \* Excel.
- \* HP BenchLink. software

The DMM, function generator, and oscilloscope are connected to the PC via GP-IB. The PC's have HP BenchLink software to enable interactive control of the DMM, function generator, and oscilloscope.

Additionally, each student team is assigned a toolbox that contains a solderless breadboard and all the basic components used in the experiments : resistor, capacitors, LED's, op-amp, ect.

To support the microprocessor experiments, we purchased 10 set of F68HC11 single board microcontrollers from New Micros,INC. We chose the NMIX-0029-OEM single board microcontroller because of its expandability. We also purchased 8 set of Mini Boards from S.W. Technology for ME190 student projects. A variety of add-on boards with functions such as solid-state relays, mechanical relays, stepper motor controller, servo DC motor controllers, etc. were purchased. We also purchased ten multifunction data acquisition and control boards ( Lab-PC+) from National Instruments. Each PC station is equipped with LabView software for process monitoring, control and data analysis. MATLAB software and Excel software are used for dynamic system analysis and data analysis. Eight sets of DMM, power supply, Function generator, oscilloscope, personal computer and printer are donated by HP Company.

#### **4. Summary**

The Mechatronics Engineering Laboratory ( ME ) at San Jose State University is one of the major elements of an NSF sponsored award to develop an undergraduate curriculum stem in Mechatronics System Engineering . This lab will support instruction of two new courses : ME 106 and ME 190 .The ME Lab consists of eight workstations equipped with basic test and measurement instruments. Each workstation is also equipped with data acquisition and control software for system simulation , control design and implementation and data analysis. The ME Lab has been designed to enable teams of two to three students to gain significant hands-on learning in Mechatronics. The new ME laboratory and the six existing laboratories of the Mechanical Engineering Department (Automatic Control Laboratory, Automated manufacturing Laboratory, Microfabrication Laboratory, Electronic System Cooling laboratory, Electronic Packaging Laboratory, Acoustic and Noise Measurement Laboratory) will provide strong hands-on study for the students in the mechatronics System Engineering stem.

#### **Acknowledgments**

The authors would like to thank the Advisory Committee and Industry Advisors for their support of the development of the Mechatronics Engineering Laboratory. Of special note is Mr. Ed Muns of the Hewlett-Packard Corporation who facilitated a generous donation of HP Test and Measurement equipment to the ME Lab. We thanks OMRON Company ( Mike Gaskill ), Oriental Motor ( Gary Grove ), Contect USA ( J. Mizuno ) for



their generous donation of automation control equipments and their valuable time for helping us in development of the laboratories. We also recognize the help of our student assistants : Joe Christman, Doug Sprock, Han Sing, Mike Kerney, and Marvin Lam, in the development of the laboratory experiments. Our administrative assistant, Dorothy Lush, and our technicians Lou Schallberger and Tom Ng. Financial support from the National Science Foundation is specially acknowledged.

## **REFERENCES**

- [1] Hsu, T.R. " Mechatronics for Undergraduate Mechanical Engineering Education," 1995 ASEE Annual Conference Proceeding, Vol.1, pp1312-1324.
- [2] Dias-Ferreira, L.Ma, T.Pinckney, and M.Lam, " Mechatronics Experiment Manual," Electrical Engineering Department, San Jose State University. December, 1996.
- [3] Reyes, N., Kong, N., Tai, W., Ramos, M. and Lee, E., " Design of Closed-Loop Robotic System with Force Feedback Sensors," Senior Project report. Mechanical Engineering Department. San Jose State University. December, 1992.

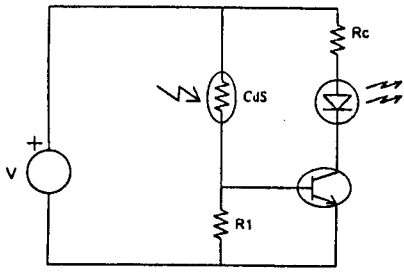

Fig. 1 Experiment #1

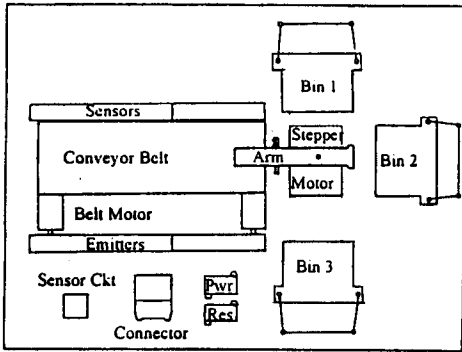

Fig. 2 Experiments #11 and #12

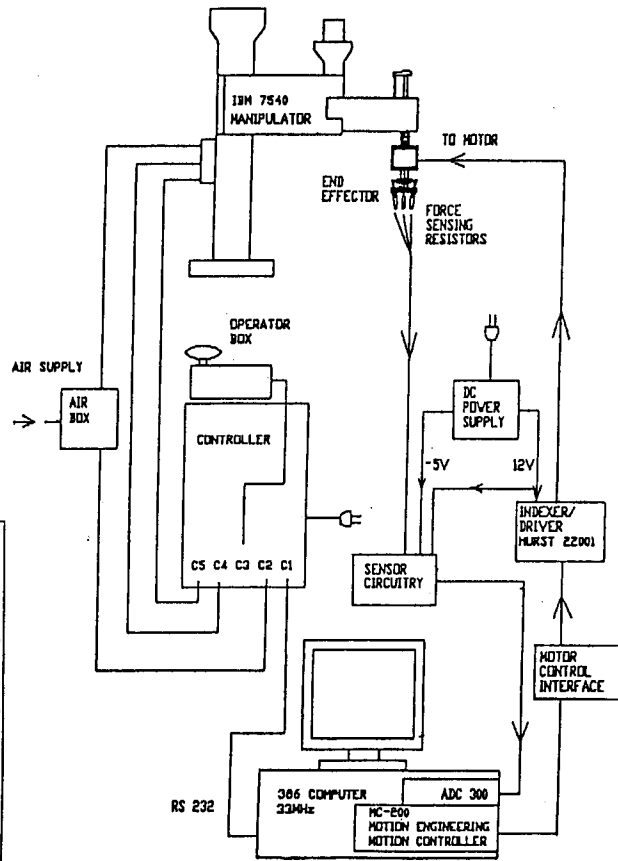

Fig. 3 A Student Project

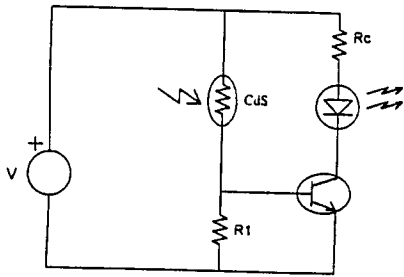

Fig.1 Experiment #1

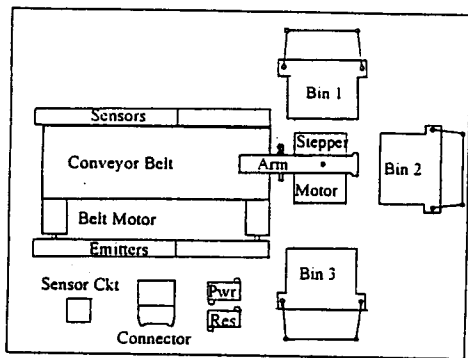

Fig.2 Experiment #11 and 12

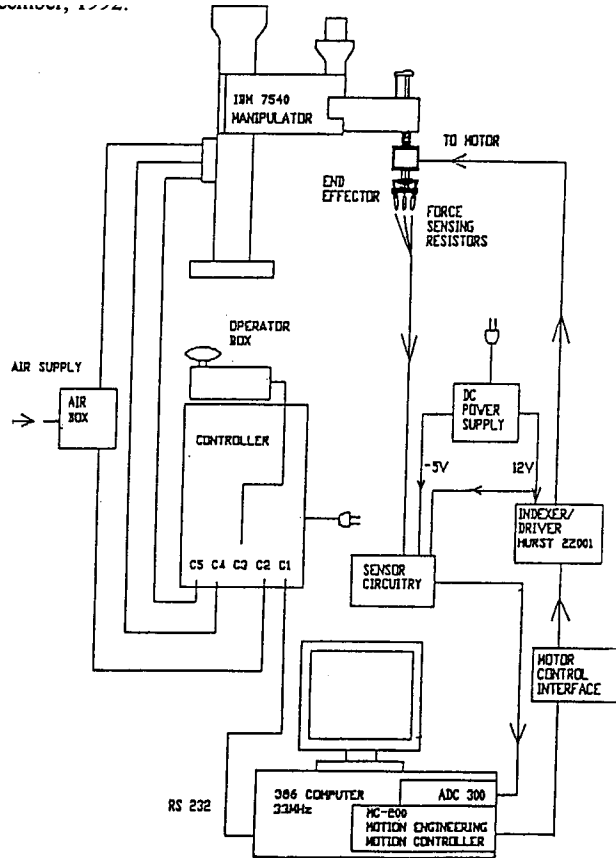

Fig.3 A Student Project

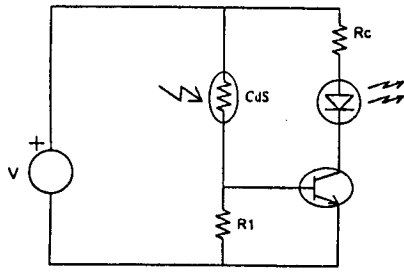

Fig. 1 Experiment #1

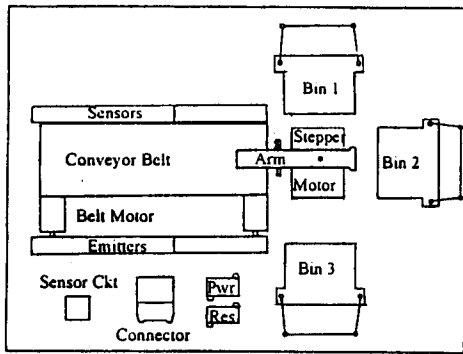

Fig. 2 Experiments #11 and #12

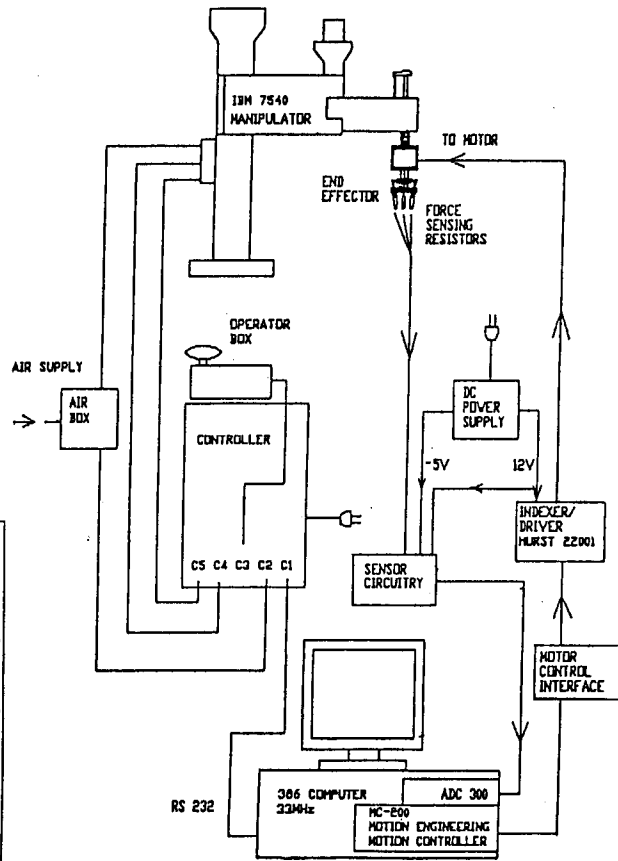

Fig. 3 A Student Project

Session 3666 Mechatronics Engineering Laboratory Development at San Jose State University J.C.Wang, B.J.Furman, T.R. Hsu, P.Hsu, P.Reischl and F.Barez Departments of Electrical Engineering and Mechanical Engineering San Jose State University San Jose, California, 95192. USA. Abstract The Mechanical Engineering Department of San Jose State University has been developing a new mechatronics engineering laboratory since Fall 1995. This laboratory is intended to provide engineering students on the application of electronics, microprocessors and software in designing electro-mechanical systems , mec... Engineering and System Engineering of Objects of Marine Infrastructure Social philosophy Social Sciences Social Work Sociology Software and Administration of Information Systems Software Engineering Soil Science Special (Defektology) Education Sport Standartization and Metrology State and Municipal Administration Stomatology Surgery System Analysis and Management Technical Operation of Aircraft and Engines Technical Physics Technological Machinery and Equipment Technologies of Materials Technology Construction Engineering Technology Logging.Â Mechatronics and Robotics. National Research ITMO University. General information. San JosÃ© State University College of Engineering. Site Navigation. About Us. Message from the Chair. About ME. Mission. Distinguished Alumni.Â Mechatronics engineering (eng 125). Director: Dr. Furman Classes Served: ME 106, 195. Spartan Superway. Director: Dr. Furman. Solar pyronameter used for measuring solar irradiance (Renewable Energy Lab). Sample prototypes from Stratasy's Prodigy Plus (Product Design Lab). Anechoic chamber (Acoustics and Precision Measurements Lab). San Jose State University, San Jose, California. 65,728 likes Â· 423 talking about this Â· 296,614 were here. Welcome to the official San JosÃ© State...Â San JosÃ© State University is a major, comprehensive public university located in the heart of Silico See More. Community See All. 65,728 people like this. 70,736 people follow this. 296,614 check-ins. About See All. The Mechanical Engineering Department of San Jose State University has been developing a new mechatronics engineering laboratory since Fall 1995. This laboratory is intended to provide engineering students on the application of electronics, microprocessors and software in designing electro-mechanical systems , mechatronics products and process control systems.Â Since the development of the Mechatronics Engineering laboratory was carried out in conjunction with the curriculum development of ME 106 and ME 190, it will be helpful to discuss both in this section.